

# BITUMEN TRANSFER PUMP SKID

*A fully customisable, bespoke pump skid solution for rapid discharge or loading of bitumen*

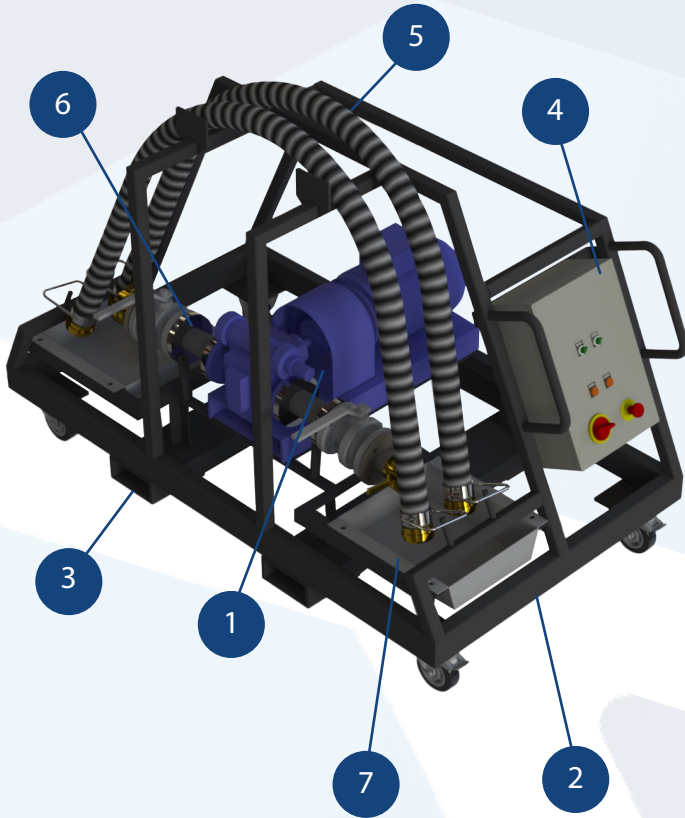

## Features & Benefits

Robust and durable design for longevity and reliability



Ideal for loading road tankers or Bitutainers™ on site



Completely bespoke solution to meet your specific requirements

## Main Features

No.	Item	Qty	Description
1.	HD5 Pump	1	28 m <sup>3</sup> /h, cartridge heated pump, specific for bitumen and bitumen emulsions.
2.	Transfer Pump Skid	1	Painted carbon steel frame, equipped with handle and wheels for improved mobility. Built in hose stand, allowing for perfect drainage after every use.
3.	Integrated Forklift Pockets	2	Integrated forklift pockets, allowing for safe lifting operation.
4.	Control Panel for Transfer Pump	1	Integrated control panel.
5.	3" Hose 3m Long	2	3m long transfer hoses included as standard. <i>Quick connection fittings to the pump in one end, to suit customer specification opposite end.</i>
	Hose to Pump Connector	2	
6.	2-way manual ball valve 3" Pump to Valve Flexible Connections	2 2	Isolation valves at both suction and discharge sides of the pump.
7.	Drip Trays	2	Trays to collect product drip included. Removable and easy to clean.